

# MODEL CD-16 DISPENSER

Plastic Strapping Dispenser



## FEATURES

- Electronic brake to control dispenser refill
- Capable of using both PP and PET strapping on 16" x 6" core ID
- Integrated strap accumulator maintains control of slack strap at all times
- Reduces wear on strapping heads since strap is pulled from accumulator not directly from strap coil
- Simple mechanical locking mechanism for strap threading
- Can be used on virtually any strapping machine

# MODEL CD-16 DISPENSER

## Plastic Strapping Dispenser

### SPECIFICATIONS

<b>Strap Type</b>	PP or PET for operation with automatic machines	
<b>Strap Width</b>	9 to 16 mm	$\frac{3}{8}$ " to $\frac{5}{8}$ "
<b>Strap Thickness</b>	0.5 to 0.9 mm	.019" to .035 s/b .040"
<b>Strap Accumulator Capacity</b>	20.1 m	66 ft
<b>Power Supply</b>	24 V	

© C-16-124702-2/18.  
Specifications are for guidance purposes only and subject to change without notice.

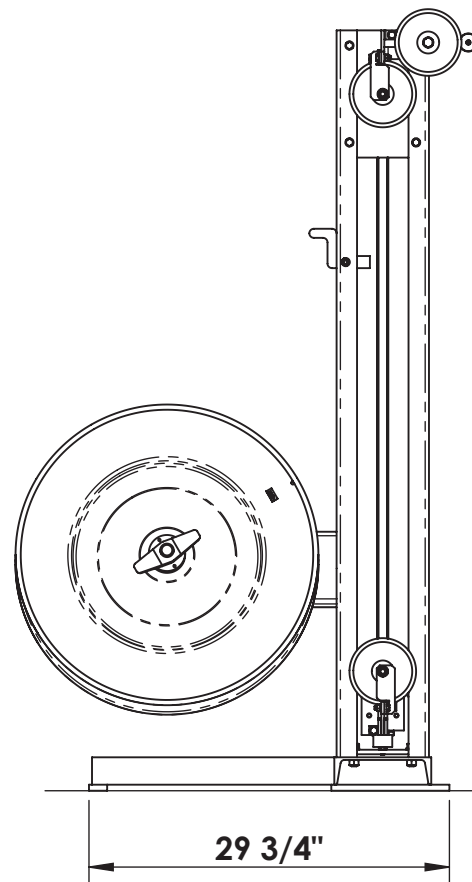
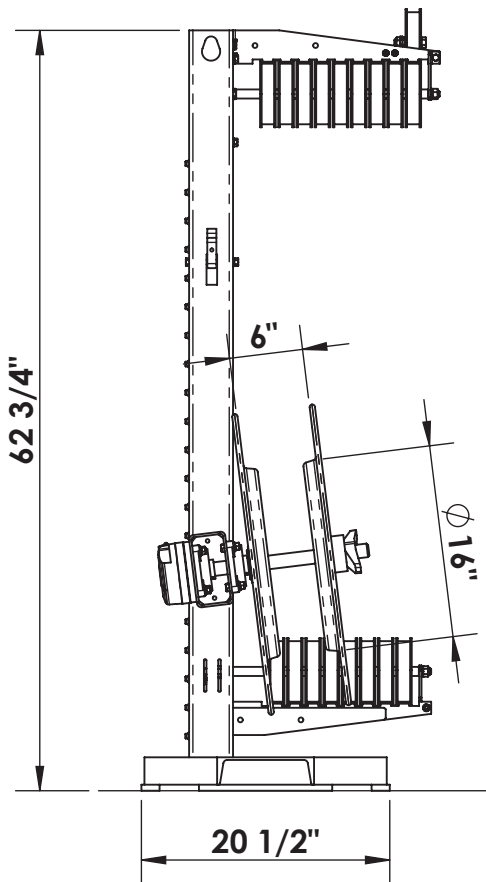
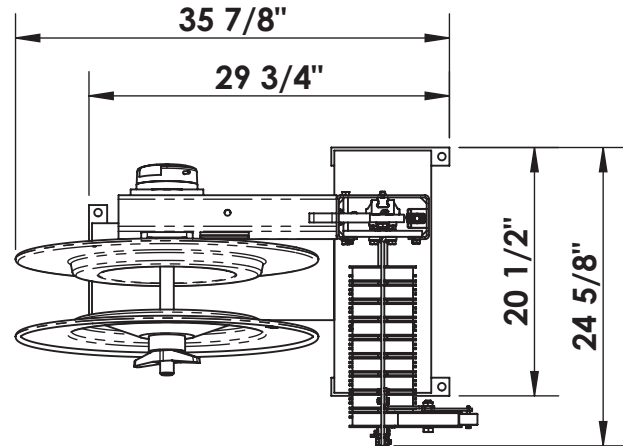

We invite you to experience the Samuel advantage by contacting us today!

[packaging@samuel.com](mailto:packaging@samuel.com)

Canada: 800-607-8727

U.S.: 800-323-4424

**SAMUEL**  
1855  
PACKAGING SYSTEMS GROUP